



# V Rose Microsystems, Inc.

[www.vrosemicrosystems.com](http://www.vrosemicrosystems.com)

**VRM-MCH**

## Product Data Sheet

### Overview:

The VRM-MCH is a MicroTCA (uTCA/MTCA) Carrier Hub in the form factor of a single width and single or double height Advanced Mezzanine Card (AMC). It provides the central management and data switching entity for all MicroTCA systems. The VRM-MCH comprises of a base module and numerous optional daughter cards which can be mounted on the base module. The VRM-MCH is MicroTCA.0 R1.0 compliant and delivers switching and hub functionality for the various system fabrics as defined in the AMC.x standard series, i.e. 1Gigabit Ethernet, PCI-Express (PCIe), Serial Rapid I/O (SRIO), 10Gigabit Ethernet (XAUI) or Serial Attached SCSI (SAS). The VRM-MCH can also provide a centralized clock distribution to all AMCs in the system.

**CPU, memory and O/S:** The VRM-MCH base board is equipped with a CPU of the Freescale ColdFire family of processors. The CPU operates at core frequency of 200 MHz. The VRM-MCH provides 32/64MB SDRAM and 16/32/64MB FLASH memory. The operating system used with the VRM-MCH is OK1 or Linux.

**Gigabit Ethernet Switch and 10GbE (XAUI) Support:** The Gigabit Ethernet Switches incorporated in the VRM-MCH both provide a layer 2, non-blocking, low-latency Gigabit Ethernet switches, supporting VLAN as well as a port based rate control. The VRM-MCH supports Fabric A (1GbE) and Fabrics D-G (10GbE/XAUI) according to MicroTCA.0 R1.0 and PICMG SFP.1 R1.0, serving up to 12 AMCs as well as the update channel from the second MCH in redundant environments. Also supported are uplink ports at the front panel of the VRM-MCH to interconnect to other carriers, shelves or systems.

**PCI Express Hub and Switch:** The PCI Express Switching option allows PCIe connectivity for up to 12 AMCs at PCIe rates from x1 to x4. The used PCIe chipsets provide a Quality of Service (QoS) module and are configurable in terms of a non-transparent port for multi-Host support. The PCIe option can optionally provide a PCIe clock by a Spread Spectrum Clock (100MHz mean) or a fixed 100MHz clock. The clock can be compliant to HCSL or MLVDS signaling levels. The PCIe hub provides clustering for two independent clusters of 6 slots.

**Clock Distribution:** Besides the PCIe clock the VRM-MCH also offers a sophisticated clock distribution module for special requirements, i.e. as by comms applications. Thus the module allows a flexible selection of the telecom and non-telecom clocking structures as defined in MicroTCA.0 R1.0. The on-board Stratum 3 type PLL sources its clock reference configurable from either any of the 12 AMCs or from an external clock via the front panel BNC type connector. With respect to the PCIe clock the VRM-MCH supports both signal levels, HSCL as required by PCI-SIG and MLVDS as requested by the microTCA.0 specification.



**SRIO Hub Module:** Alternatively to PCIe or 10GbE (XAUI) the VRM-MCH can be equipped with a Serial Rapid I/O daughter board to support contention less point-to-point connectivity between up to 12 AMC modules. The SRIO hub supports x1 and X4 fat pipe transport density.

**Carrier Manager:** Management of up to 12 AMCs, 2 cooling units and 1-4 power units, supports redundant architectures and fail-over.

**Shelf and System Manager:** For detached or stand-alone operation both managers are available on-board, hook-in for external managers via 100BaseT port at front panel

### Features:

#### **CPU and memory**

Freescale ColdFire 547x @ 200MHz  
DRAM: 32/64MB | FLASH: 16/32/64MB

#### **IPMI and Compliance**

12 AMCs,  
2 cooling units  
1-4 power units  
PICMG AMC.0 R1.0  
PICMG 2.9 R1.0



### Features:

#### Supported Fabrics and Compliance

Fabric A: Gigabit Ethernet  
 12 AMCs  
 PICMG AMC.2 R1.0  
 PICMG SFP.1 R1.0

#### Fabric B: Serial Attached SCSI

Serial ATA  
 PICMG AMC.3 R1.0  
 option available on request

#### Fabric D-G:

PCI Express (PICMG AMC.1 R1.0)  
 12 AMCs, x1-x4 each  
 Serial Rapid I/O (PICMG AMC.4)  
 10GbE (XAUI) (PICMG AMC.2)

#### Clock Distribution:

Telecom: Stratum 3 PLL with reference from either 1 of the 12 AMCs or external clock via front panel  
 PCIe: Spread Spectrum Clock (100MHz mean) or oscillator (100MHz fixed), HCSL or MLVDS signaling

#### Operating System and API

O/S: OK1, Linux  
 API: HPI compliant

#### Indicator LEDs

4 standard AMC LEDs  
 12 bi-colour LEDs for AMC slot status  
 2 bi-colour LEDs for cooling units  
 2 bi-colour LEDs for power units

#### Front Panel Connectors

100 BaseT management connection  
 1 GbE system up-link for Fabric A  
 external clock reference (bi-directional)  
 serial debug connector

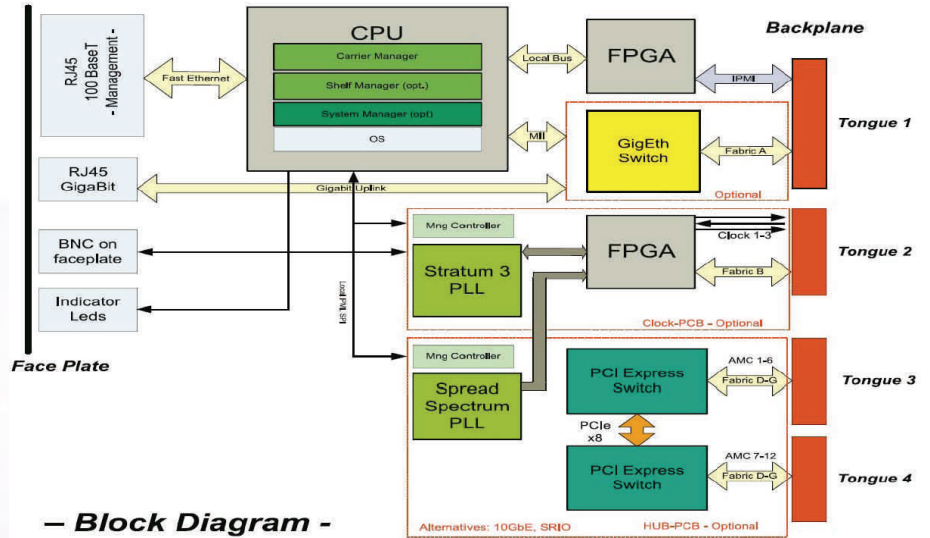

- Block Diagram -

### Ordering:

- VRM-MCH-Base6:** Base module for 6 AMCs, MCH basic management module for 6 AMC boards - no Hub functionality.
- VRM-MCH-Base12:** Base module for 12 AMCs, MCH basic management module for 6 AMC boards - no Hub functionality.
- VRM-MCH-Gbe:** Gigabit Ethernet at Fabric A, Gigabit Ethernet Hub for Fabric A with uplink on front panel and update link to 2nd MCH.
- VRM-MCH-TCTCXO:** Telecom Clock Module - Stratum 3, Telecom clock module supporting CLKs 1,2 and 3. CLK2 of one of the 12 AMC modules or the front panel clock input can be selected as reference clock input for CLK1/3.
- VRM-MCH-TCOCXO:** Telecom Clock Module - Stratum 3e, Telecom clock module supporting CLKs 1,2 and 3 with oven heated oscillator. CLK2 of one of the 12 AMC modules or the front panel clock input can be selected as reference clock input for CLK1/3.
- VRM-MCH-SSCM:** PCIe Spread Spectrum Clock - MLVDS, Clock Module supporting a PCIe Spread Spectrum Clock (100MHz mean) on CLK3 to all AMCs - MLVDS Signal level and termination (uTCA R1.0) - Not recommended for new designs.
- VRM-MCH-SSCH:** PCIe Spread Spectrum Clock - HCSL, Clock Module supporting a PCIe Spread Spectrum Clock (100MHz mean) on CLK3 to all AMCs HCSI Signal Level and termination - PCIe compliant - recommended for new designs
- VRM-MCH-PCIex24:** PCIe Switch for Fabric D-G, PCIe x4 switch for 6 AMC modules. Update channel for fabrics D/E.
- VRM-MCH-PCIex48:** PCIe Switch for Fabric D-G, PCIe x4 switch for 12 AMC modules. Update channel for fabrics F/G.
- VRM-MCH-SRIOx24:** Serial Rapid I/O Hub Module for Fabric D-G, Serial Rapid I/O Hub module with support for 6 AMC modules.
- VRM-MCH-SRIOx48:** Serial Rapid I/O Hub Module for Fabric D-G, Serial Rapid I/O Hub module with support for 12 AMC modules.
- VRM-MCH-XAUIx24:** 10GbE Hub Module for Fabric D-G, Serial Rapid I/O Hub module with support for 6 AMC modules.
- VRM-MCH-XAUIx48:** 10GbE Hub Module for Fabric D-G, Serial Rapid I/O Hub module with support for 12 AMC modules