



# V Rose Microsystems, Inc.

[www.vrosemicrosystems.com](http://www.vrosemicrosystems.com)

**VRM-AMC-6487C**

## Product Data Sheet

### Overview:

**V Rose Microsystems** AMC-6487C is a single width, full-height Advanced Mezzanine Card offering unprecedented signal processing performance and bandwidth in a highly compact package, for the latest wireless telecom applications. A total of nine 1GHz DSP cores and a large FPGA allow an application to be partitioned and optimised for most effective use of system resources.

A 10Gbps SRIO infrastructure based on the PICMG AMC.4 standard provides the deterministic bandwidth needed for data transfers on and off card. A separate three link full-duplex CPRI/OBSAI compliant antenna interface, with configurable clocking and synchronisation, provides additional interface capabilities targeted to wireless radios. An AMC.2 Gigabit Ethernet is provided for OA&M and transport of processed data streams. Additional high speed user-configurable I/O is provided to the backplane or optionally front panel via multiple highspeed serial ports from the FPGA.



### Features:

- 3 Texas Instruments TMS320TC16487 DSPs each with 3 1GHz C64x+ cores
- Xilinx Virtex-4 FX100 FPGA, customer programmable. Optional in volume
- Tundra Tsi578 Serial RapidIO Switch for full SRIO infrastructure including DSPs, FPGA, AMC.4 and front panel
- Over 768MB total card memory
- Full Gigabit Ethernet infrastructure
- CPRI and OBSAI compliant front panel antenna interface
- Single width, full height PICMG AMC.0 R2.0 Advanced Mezzanine Card
- Software and firmware library support
- Developed for use in OEM products
- Fully supported with customization options and OEM lifecycle services
- High performance DSP resource for wireless baseband processing
- Additional I/O, pre-processing or signal processing resource
- Dependable low-latency high-bandwidth interconnect, both on and off card, at up to 10Gbps per link
- Extensive data storage
- Industry standard interconnect
- Industry standard links to wireless radio remote heads
- Works with Industry standard MicroTCA and AdvancedTCA systems
- Fast route to application code porting
- Reduces integration risk and speeds time to market
- Allows a detailed fit to specific OEM requirements



# V Rose Microsystems, Inc.

www.vrosemicrosystems.com

**VRM-AMC-6487C**

## Product Data Sheet

### Hardware:

#### **DSPs: 3 x TMS320TCI6487, each with:**

- Three 1GHz C64x+ DSP cores
- 256MB DDR2-667 SDRAM, boot EEPROM
- 5Gbps SRIO and Gigabit Ethernet
- GPIO, McBSP & MMC connections

#### **Antenna Interface:** 3 x CPRI/OBSAI compliant full-duplex links:

- Data rate up to 3.072Gbps per link
- Chained through DSP array
- External clock/F-pulse interface

#### **FPGA:** Xilinx Virtex-4TM FX100 FPGA with:

- 9 or 18Mbytes x36 200MHz SRAM
- 10Gbps 4x SRIO
- 2 Full-duplex Gigabit Ethernet ports
- RocketIOTM connections to AMC ports 12-13 and 17-20
- Optional 10Gbps Front Panel RocketIO
- Optional Chipscope header

#### **Serial RapidIO:** 10Gbps 4x infrastructure using Tundra Tsi578TM switch:

- AMC.4 compliant 10Gbps 4x connections to AMC ports 4-7 and 8-11
- 2 dedicated 2.5Gbps 1x links to all DSPs
- Dedicated 10Gbps 4x link to FPGA
- Front Panel 10Gbps 4x Connector

#### **Ethernet:** Gigabit Ethernet infrastructure using Broadcom BCM5389TM switch:

- AMC.2 (1000BASE-BX) compliant connections to AMC Ports 0 & 1
- Full-duplex 1Gbps links
- 9300 byte Jumbo Packet support
- FPGA & AMC Fabric port pairs

#### **IPMI:** ATmega128 IPMI controller:

- AMC.0 IPMB\_L interface
- FRU EEPROM data
- Power and reset control
- Real-time health monitoring

#### **Form Factor:** Advanced Mezzanine Card

- AMC.0 Rev 2.0 compliant
- Full-height, single-width
- Usable in both AdvancedTCATM and MicroTCATM systems.
- AMC.2 Gigabit Ethernet
- AMC.4 4x Serial RapidIO
- Hot swap support

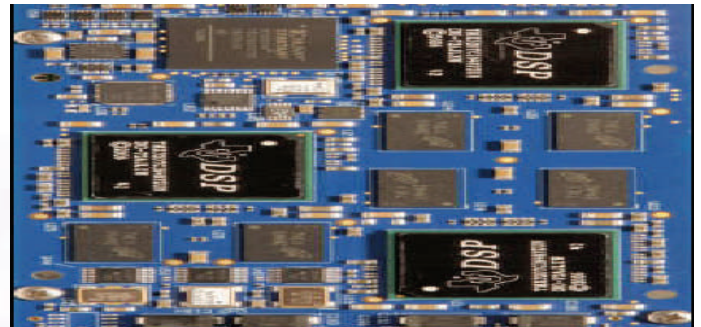

### **Configuration and Debug:**

- DSP boot: EEPROM, Ethernet or SRIO
- FPGA loaded from DSP via SelectMap
- On-board debug LEDs for DSPs, FPGA, power and Ethernet ports
- Debug connector and breakout board for XDS-510, Xilinx platform cable, DSP and MMC serial ports

### **Environmental/EMC/Safety:**

- Operating temperature: 0-40 oC ambient
- Power consumption: up to 48W, dependent on software and FPGA load
- Designed for NEBS and ETSI compliance when used in appropriate chassis
- 2004/108/EC and FCC EMC compliant
- 2002/95/EC RoHS, 2002/96/EC WEEE and 2006/95/EC Low Voltage Directive Compliant

### **Software Specifications:**

- DSP Board Support Library (BSL): support for controlling board functions, interfaces and self test
- TCP/IP stack also available for DSPs
- FPGA: to demonstrate configuration and functionality; Xilinx ISE project
- MMC: full management suite based on Pigeon-Point BMR software



# V Rose Microsystems, Inc.

www.vrosemicrosystems.com

**VRM-AMC-6487C**

## Product Data Sheet

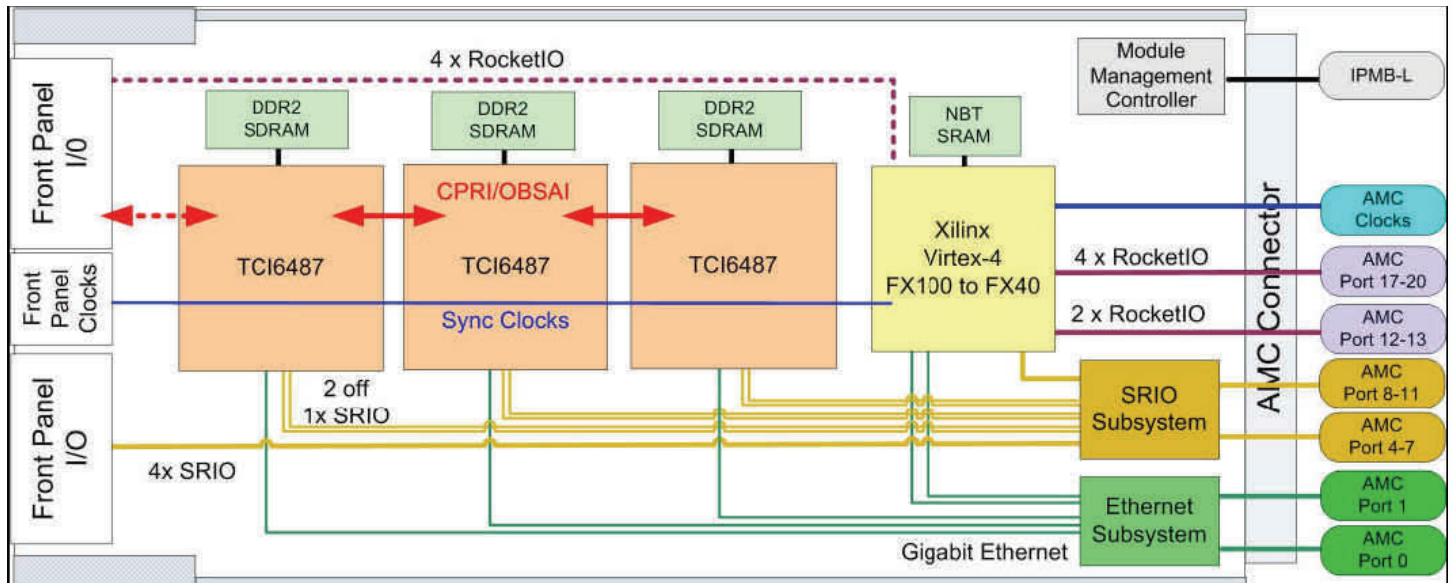

### Ordering:

**VRM-AMC-6487C:** High performance signal processing card for wireless baseband solutions (WiMax and LTE)

**AdvancedMC™**

**AdvancedTCA®**

**μTCA™**